



Screwdriving Technology

Automation

Air Motors

Air Tools

**DEPRAG**  
machines unlimited

## End-of-Arm-Tooling for Grinding and Polishing

- efficiency
- flexibility
- precision
- highly durable

Our air stationary grinder is designed as a customised customer solution to be used in a connection with an industrial robot, especially in mass productions.

The special grinding head is designed to hold a DEPRAG INDUSTRIAL grinding spindle and is equipped with a flange for subsequent connection to the selected industrial robot. In order to reach optimal grinding characteristics, the downforce of the spindle holding the grinding insert is regulated by air.

### Applications

- grinding and polishing of flat or curved surfaces in the automotive industry
- treatment of forms, dies and punches
- finishing of different types of cast iron parts, welding seams, deburring of edges or any other surface work in various industries and hard-to-access areas



**DEPRAG CZ a.s.**  
- Your Partner  
for Grinding Technology

Would you like to increase the efficiency and productivity of your production? Do you have a high waste rate in your production? Are you thinking about installing a robot to your production in order to lower your costs?

### DEPRAG CZ a.s offers:

- independent consultation in your facilities and evaluation of the possibility to use an industrial robot for grinding and polishing applications
- price quotation including a 3-D model
- selection and testing of all components for optimum grinding or polishing results
- complete engineering services incl. design, production, assembly and integration to your production process



## SPECIFICATIONS - STATIONARY GRINDER

### Design

Dimensional-sketch (mm)

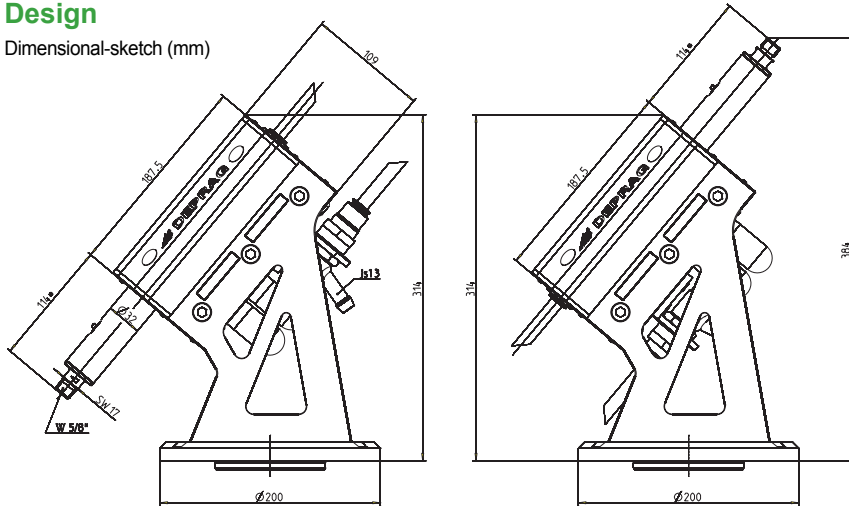

DESIGN A \* fully extended (Stroke = 20 mm/.79 in) DESIGN B



Stationary Grinder	Model	MA070-153V/S1	
Remote Valve	Part No.	6061302A	
Max. power output	kW (hp)	0,7	(.94)
Speed (no load)	min <sup>-1</sup> (rpm)	15 300	
Air consumption (no load)	m <sup>3</sup> /min (cfm)	0,28	(9.89)
Air consumption (at max. power)	m <sup>3</sup> /min (cfm)	0,7	(24.72)
Total weight with the extension	kg (lbs)	12,9	(28.4)
Weight - head Part No. 6022533A	kg (lbs)	5,45	(12.0)
Working stroke	mm (in)	20	(.79)
I.D. of air inlet hose	mm (in)	Lw 10	(.39)
Max. grinding disc-Ø	mm (in)	100	(3.9)
Sound pressure level LpA according ČSN EN ISO 15744	dB(A)	84 (uncertainty of measurement 3 dB)	
Sound pressure power LwA according ČSN EN ISO 15744	dB(A)	95 (uncertainty of measurement 3 dB)	

Specifications at 90 psi (6,3 bar)

### Standard Equipment:

Spanner 17 mm

### Part Number

800405

### Force

#### Force (bar)

0,5  
1  
2  
3  
4  
5  
6  
6,3

#### Power (N)

5  
13  
24  
36  
47  
59  
73  
75

**DEPRAG**  
machines unlimited

