

E-MOBILITY

ASSEMBLY SOLUTIONS



KEY COMPONENTS

E-MOBILITY

- Body in white, bodywork chassis
- Electric motors and gears
- Battery pack
- Battery housing
- Control and power electronics
 - Inverter
 - OBC on board charger
 - BMS battery management system
 - IGBT



E-mobility imposes certain requirements on the assembly process: top process reliability for safety-related components, high flexibility due to the wide ranging variety, requirements for traceability and targeted reliable electro-static discharge (ESD capability) of system components. In addition, these components require an assembly environment which fulfils the guidelines of technical cleanliness and also scores highly on ergonomic and safety aspects.

The complexity of the different tasks is a challenge to a budget-friendly approach. The solution: **DEPRAG – your innovative partner in the field of E-mobility.**

From components and manual work stations, up to semi or fully-automatic assembly systems, we provide flexible assembly solutions for all stages of expansion, which can all be adapted to the current market situation at any time. This flexibility specifically counteracts planning uncertainties and enables reactive responses to changing requirements.



**Products for all stages of expansion,
from one source, available internationally!**

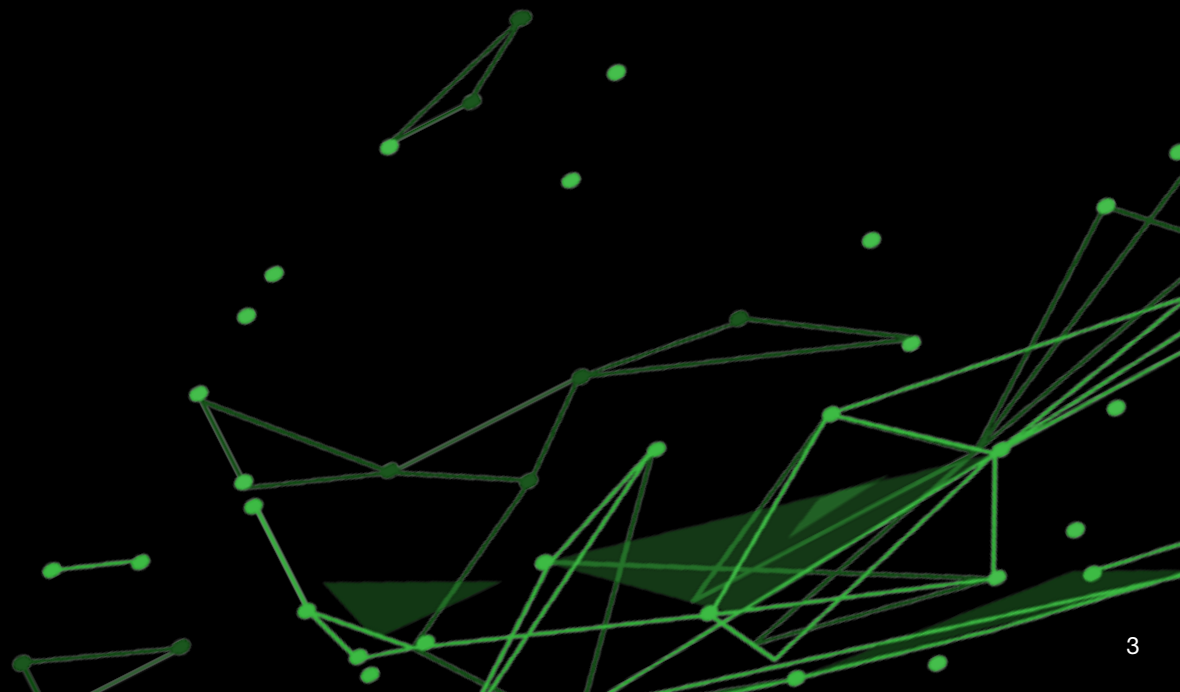



ASSEMBLY

BATTERY PACK

The innovative high voltage components of an electric vehicle present unseen challenges for production assembly. The integration of high voltage components demands radically new solutions. In addition, the issue of high voltage in the assembly process needs to be taken into account.

Electric vehicles have significantly higher voltages (up to 800 volt direct current). This requires higher safety measures for operators in the assembly process.

During battery assembly, the cell module is assembled first. The individual battery cells are stacked, placed in the battery housing and connected to the battery management system. In a next step the current collector is connected to the power supply, the wiring is checked and the housing closed. Subsequently, the power supply and contacts are connected before the finished modules are tested. The individual cell modules are fixed to a floor element via contact rails and assembled with fasteners. Finally, electronic boards and seals can be attached.

- Installation of the module requires complete traceability.
- The battery size and resulting high number of assemblies is usually automated and has short cycle times.
- Avoidance of particle contamination.
- Safety for operators: contact with live power circuits can cause serious, even deadly, injuries.

Insulated screwdriving tools

DEPRAG insulation concept:

- special ceramic and synthetic parts
- protects against voltage of up to 1000 volts

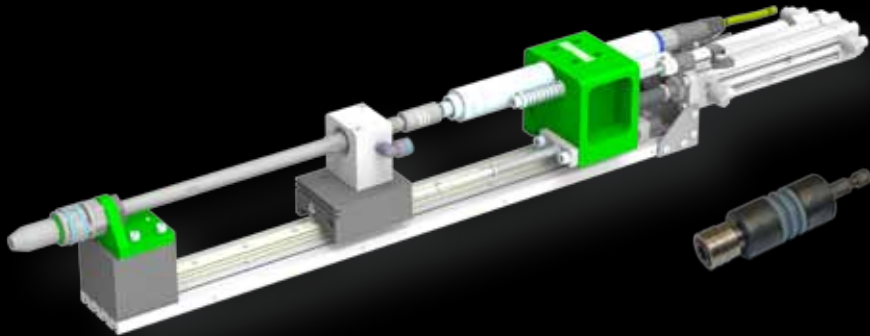

Safety at work:

Insulated solutions protect both the operator and tool from electric shocks. The applicable standards are met e.g.

- ISO 6469-3

Electrically propelled road vehicles – Safety specifications – Part 3: Electrical safety

- DIN EN IEC 60900 (VDE 0682-201)

Live working; Hand tools for use up to 1000 V AC and 1500 V DC

and many more. Of course, we work to your specifications and can react flexibly to the standards required in the field of E-mobility.

Traceability:

Adaptive screwdriving procedures, to guarantee complete traceability.

Technical cleanliness:

DEPRAG CleanFeed concept with screwdriving function module with vacuum suction and screw feeding via step feeding system.

Multi-spindle version for short cycle times

Gripper jaws to avoid dropping the screw



Screw feeding systems to increase productivity:
step feeding system easy step feed



ASSEMBLY

POWER ELECTRONICS

Technical cleanliness is of paramount importance for assembling electronic components and modules in the field of power electronics and particularly in the field of high voltage components: particle contamination can quickly lead to insulation errors, mechanical contact blockages, undermining or interruption of light barriers for highly sensitive components in power electronics.

The critical particles may be created directly within the process, due to both the high number of components introduced into the process and the assembly steps themselves. Conductive particles in particular may cause high voltage arc flashes and short circuits.

Due to the complex design of individual components the operator may often have to deal with screw positions which are difficult to access and which must be assembled in a specific sequential order.

- Technical cleanliness
- Difficult to access screw positions
- Worker safety
- Safety-critical assemblies of category A
- Correct sequential order of assemblies
- ESD design



Technical cleanliness



DEPRAG particle killer:
dirt particles are targeted and removed
from the conveyor

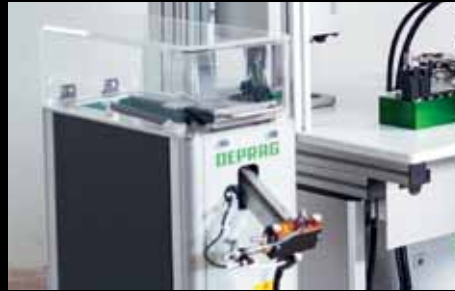

Low abrasion, gentle feeding with the
DEPRAG sword feeder



DEPRAG easy step feed
step feeder



Vacuum suction

For difficult to access screw positions



DEPRAG Feed Module DFM with vacuum:

- fatigue-free working
- optimised cycle time
- technical cleanliness

DEPRAG EC cordless tools:

- flexible
- documentation available
- user friendly
- high performance
- cordless communication



ESD capability:

ESD capable screwdrivers and accessories, e.g. feed hoses.

User friendly:

Ergonomic screwdriving tools for complex screw positions.

Traceability:

Complete traceability of the screwdriving process.

Technical cleanliness:

With the DEPRAG CleanFeed concept in all processing steps – from screw handling and feeding up to screw assembly – avoid, reduce and remove particles.

DEPRAG EC screwdriving technology:

- freely programmable screw tightening
- torque, speed and rotation can be adjusted individually to the assembly task
- high torque accuracy
- comprehensive monitoring functions
- ESD capable
- ergonomic
- documentation available





ASSEMBLY COMPONENTS

Usually screw joints of the category A in accordance with VDI standard 2862 are used for the assembly of elements in the automotive industry. Process reliability is of utmost importance and all processing steps must be documented and monitored.

The assembly process for battery module or power electronics with a wide variety of components is highly complex: numerous screws must be assembled in the correct order to guarantee a consistent pre-load force.

Within lightweight construction, especially in the field of E-mobility, aluminium, other lightweight metals and synthetic materials are increasingly used. Widely varying torques are commonly a result of the frequently employed direct assemblies. Due to different material characteristics, settling conditions can also vary. As these are predominantly conductive connections and conductivity must be guaranteed, adaptive screwdriving procedures are recommended for reliable detection of the seating point.

- Settling conditions when using varying materials.
- Screw tightening in a prescribed order to guarantee consistent pre-load force.
- Safety-critical assembly of category A.

EC-Servo technology with DEPRAG CFC Clamp Force Control



Adaptive screwdriving procedure DEPRAG CFC Clamp Force Control: despite fluctuating tightening torques, the procedure guarantees reliable detection of the seating point and ensures a consistent final position for the subsequent final tightening resulting in a constant pre-load force.

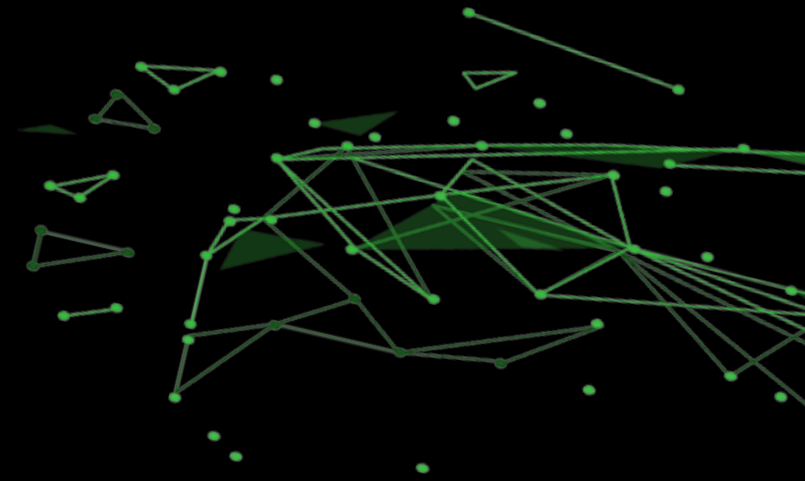

Process monitoring



Position control stand (PKS), position control gantry (PKP), camera systems

Top process reliability:

- Screwdriving procedure DEPRAG CFC Clamp Force Control: zero error production and traceability.
- Position control: correct sequence of screws for optimum quality.
- Process monitoring with camera systems.
- Complete documentation of production data.
- Visual operator guidance with DEPRAG Operator Guidance DOG.

Process visualisation with DEPRAG Operator Guidance

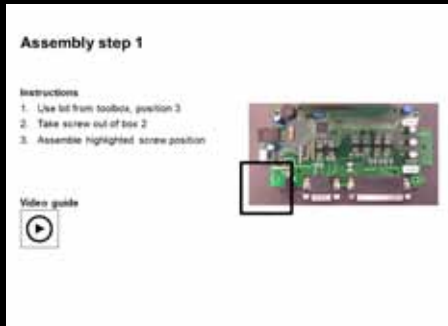

Digital assembly guides for operators: error-free assembly and traceability of all processing steps, MES communication



ASSEMBLY

BODYWORK CONSTRUCTION AND BATTERY HOUSING

Lightweight construction and the subsequent weight savings involved are amongst the greatest driving forces for innovation in bodywork construction and battery housing production within E-mobility.

As the battery is heavy, the weight of the bodywork and furnishings must be kept low. Lightweight construction materials are utilised to reduce the net weight of the vehicle and to minimize energy consumption.

Assembly and joining technology are going through radical transformation due to lightweight construction – the material mix determines the process and requires the highest possible level of flexibility from the fastening system.

The achievable travel range is the decisive factor when purchasing an electric vehicle. Lightweight construction to reduce energy consumption is a crucial issue within the field of E-mobility. The material of the bodywork presents a challenge to traditional assembly methods. Whether aluminium design or a sophisticated multi-material mix, DEPRAG has the solution.

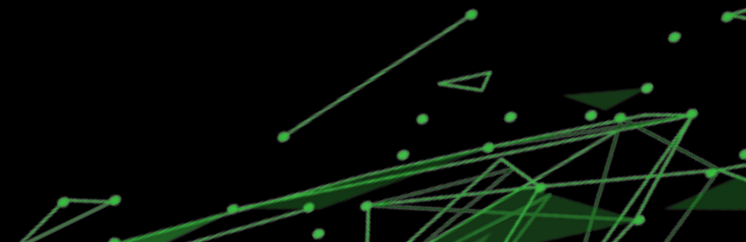

ADAPTIVE DFS DEPRAG FASTENING SYSTEM

Screwdriving system for lightweight construction assemblies

Our many years of experience and the continual expansion of our global knowledge have placed DEPRAG as a front runner and leading innovator in the development of FDS smart tools. Our patented drive technology is unique in the market and has become a game changer in the industry. Hundreds of systems operating at automobile manufacturers around the world are impressive evidence of this.

The selection of the correct fastening technology for lightweight construction is of utmost importance. Flow drill screw assemblies are the technology of choice for lightweight bodywork construction in the automobile industry. The adaptive assembly unit ADAPTIVE DFS combines EC-Servo screwdriving technology with EC-Servo feed technology. This enables automatic piercing detection throughout the flow drill assembly, independent from screw and component tolerances. The processing parameters are adjusted automatically and the processing sequence is continually optimised. The screwdriving system can be easily connected to a robot. There are no complicated and costly parameter adjustments.

- Top process reliability
- Shortest possible cycle time
- Optimised funnel forming
- Eliminates thread damage
- Low stress on screw and component
- Minimum set-up time
- Ready for new materials, fasteners and joining methods



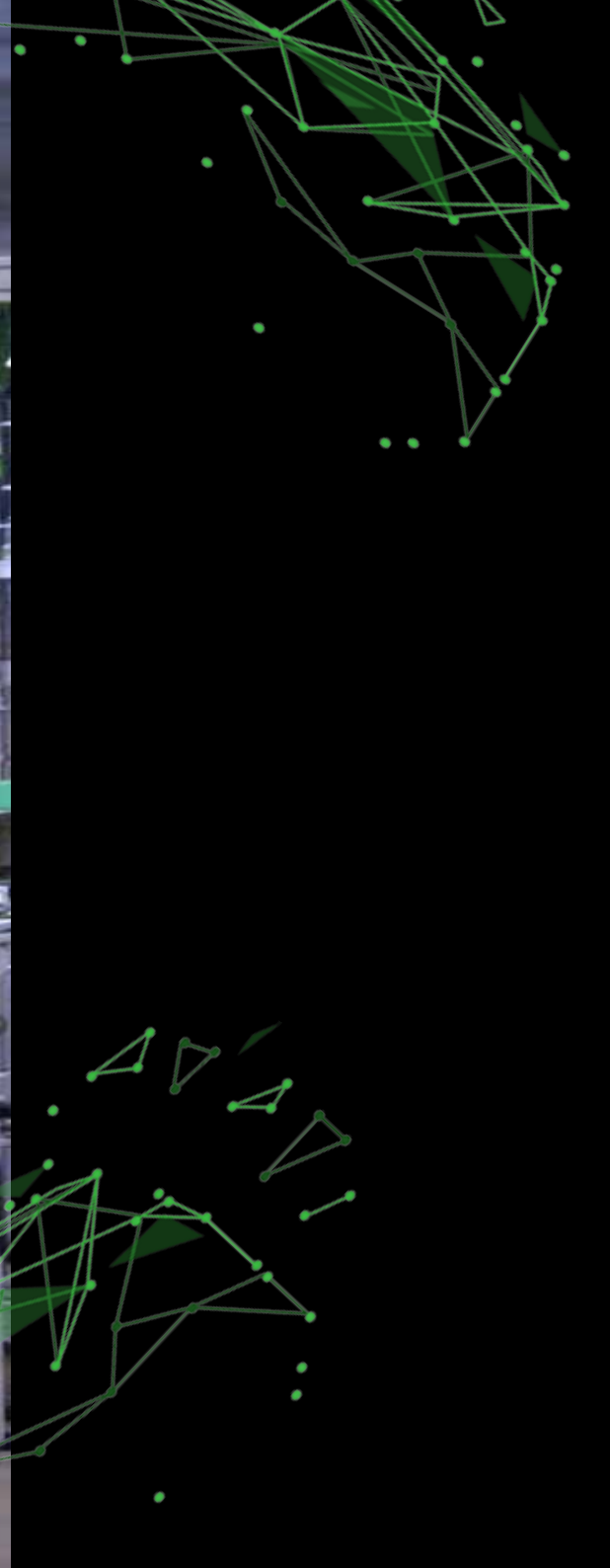

SCREWDRIVING AND ASSEMBLY SYSTEMS

From highly automated large-scale systems, fully automated assembly lines, standard assembly units right through to semi-automated reliable manual work stations, we offer an enormous range of automation solutions for E-mobility applications.

DEPRAG screwdriving and automation solutions fulfil all assembly requirements for E-mobility:

- Process reliability
- Flexibility
- Technical cleanliness
- ESD capability
- Ergonomics
- Traceability / MES

High flexibility specifically counteracts planning uncertainties and enables reactive responses to constantly changing requirements.

Please contact your DEPRAG advisor for more information.
We will find the most suitable solution for your assembly process!



DEPRAG COCKPIT

INTERCONNECTED SCREWDRIVING SYSTEMS – IT'S EASY WITH DEPRAG COCKPIT

DEPRAG Cockpit is the new digital service facilitating an easy introduction to the interconnected factory. Using the DEPRAG Cockpit, the operator is able to monitor any number of various screwdriving controllers, regardless of the manufacturer.

The software gives full access to production data from various assembly lines. The DEPRAG Cockpit as a focal point collects data from a company's various factory locations, their production lines and connected devices.

- Software for screwdriving and assembly technology
- Reliable production data acquisition
- Detailed capacity and usage statistics
- Process monitoring and notifications
- Analysis and trend detection with system messages





Your global partner for E-mobility

The DEPRAG group has production facilities in Germany, the Czech Republic and China, as well as distribution and service companies in France, Mexico, Sweden, the USA and the UK. Our network of exclusive partners in all the main industrialised countries around the world means that we are always on hand to assist our global customers.

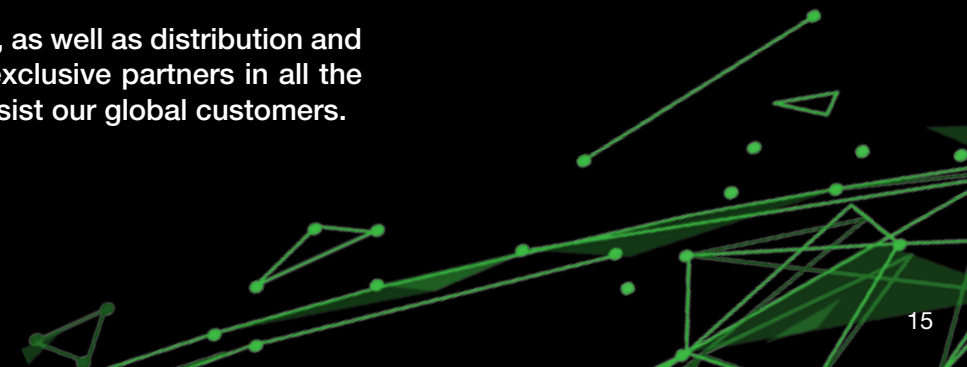

Further Informationen:
www.deprag.com

DEPRAG
machines unlimited

D0063E | 05.2021

© DEPRAG. All rights and technical alterations reserved – Fri