

Circular Letter No. 4 dated May 8th, 2013

Address: All International Offices
Pages: 3

SUBJECT: NEW PRODUCTS

Dear DEPRAG INDUSTRIAL Associate,

we would like to inform you about new products that were added to our product line. Technical information with pictures, as well as a PDF-catalog can be found on our web-site www.deprag.cz.

Contents:

- **Extension of ISO 9001:2000 Certificate**
- **Air Impact Wrench – Model SMP 110-3/4”ZA**

Extension of ISO 9001:2000 Certificate

We are pleased to inform you that our company has completed the necessary requirements to extend the expiration date of our ISO 9001:2000 certificate. The new expiration date is February 13th, 2016. Obtaining this extension from an accredited quality source, such as Bureau Veritas, shows the commitment of DEPRAG-Industrial to produce products having superior quality, while using the most modern and safety-conscience production procedures.

Air Impact Wrench – Model SMP 110-3/4”ZA

**For screws from M10 to M30
Max. torque capability 1 100 Nm**

We are proud to introduce our new air impact wrench model SMP 110-3/4”ZA that replaces the existing model PSR 30. The new SMP 110-3/4”ZA is another tool of the new generation of the DEPRAG impact wrenches. These tools are well-suited for the effective tightening of fasteners in mass-production environments, which demand high performance, utmost reliability and an extreme operational efficiency.

Model	Part Number
SMP 110-3/4”ZA	6061210A

Description:

This new impact wrench is designed to allow a fast, but low-reaction tightening of fasteners size M10 to M30. The design assures that the operation is fatigue-free, no matter if a fastener is tightened or loosened. This tool is well-suited for the use in a mass-production environment or in a maintenance department.

Robust

Versatile usability; this robust tool is suitable for the heavy industrial use for example in the automobile industry or in machine building industry.

High longevity

The robust construction secures a high lifespan of the too, even when used in 24/7 operations.

Because of the new twin-hammer impact system, a clearly better power-to-weight ratio can be reached while simultaneously achieving a lower vibration level. With the integrated torque selector switch, the torque can be comfortably set in three easy adjustments. Adjustment 1 = 920 Nm, adjustment 2 = 690 Nm, adjustment 3 = 150 Nm. In steps 2 and 3, the air consumption is automatically reduced; this increases the tools economic operation even at a lower torque setting. The maximum loosening torque is approximately 1100 Nm. Because of the newly developed drive motor, a higher torque can be reached while keeping the size of the tool to a minimum and well below the size of a comparable tool offered by our competitors. Particular attention was paid to the ergonomic design of the hand-grip. The new grip was made to assure a centered handling, which guarantees a fatigue-free operation. The reverse slide is simple to operate and easy to reach. As a standard accessory, this tool is supplied with a suspension hanger.

Advantages:

- Maximum operational power even in 24/7 operations
- Advanced motor solution – increased power output
- 3-step torque adjustment starting from 15 % of maximum working torque
- Maximum longevity and reliability
- Truly Ergonomic design
- 45 % increase of maximum torque to weight ratio compared to the predecessor PSR 30
- Lower vibration- and noise levels compared to the predecessor PSR 30
- Lower body weight
- Lower air consumption
- Simple operation

Our industrial 3/4“ air impact wrench can be used for the most demanding fabrication requirements. It is especially well-suited for the tightening and loosening of screws, sizes M10 to M30. This tool has been designed to excel in automotive- and machine-building industries. It is economical, efficient and easy for an operator to use.

Specifications:

Model	SMP 110-3/4“ZA	
For screws up to	mm	M30
Max. torque capability	Nm	1 100
Working torque range	Nm	150 - 920
Speed, unloaded	min ⁻¹	6000 ±10%
Impacts per minute	Hz	15
Air consumption no load / under load	m ³ /min	1,5 / 1,1 ±10%
Spindle – external square	mm	19 (3/4“)
I.D. of air inlet hose	mm	12
Weight	kg	4,7
Declared emission-level for acoustic-pressure A, L _{pAeq,T}	dB/20µPa	95,6 + 3
Declared emission-level for acoustic-power A, L _{wa}	dB/1pW	106,6 + 3
Vibrations a _{hv}	m/s ²	4,94 + 0,98

Specifications at 90 psi (6,3 bar)

Specifications – dimensional-sketch (mm):

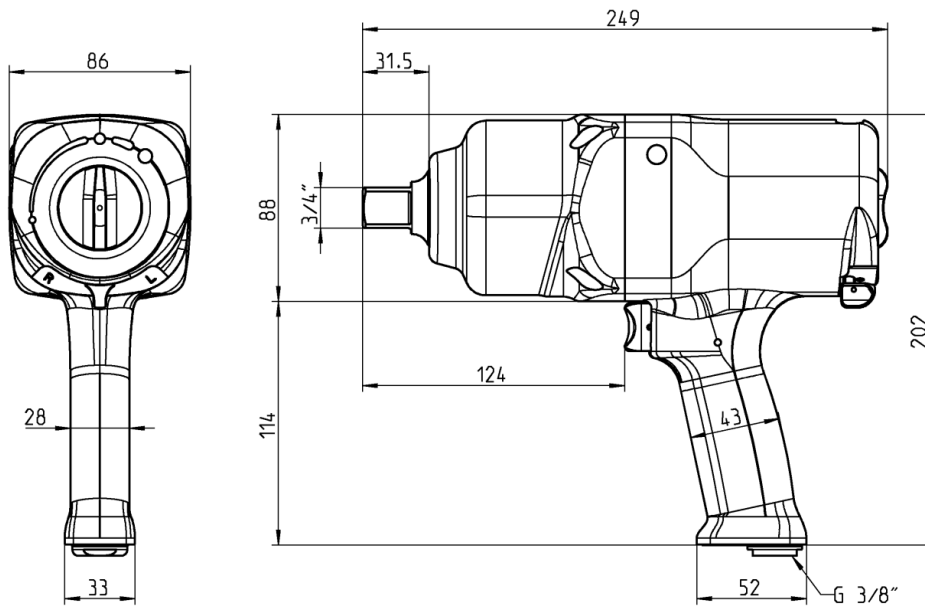

New generation of impact wrenches – Model SMP 110-3/4"ZA



SMP 110-3/4"ZA

Our impact-wrench SMP 110-3/4"ZA is a standard product of DEPRAG INDUSTRIAL.
Official date of sale: May 8th, 2013.
Effective May 8th, 2013, we replace the model PSR 30 by the new model SMP 110-3/4"ZA.